

Montageanleitung Giffin Grip

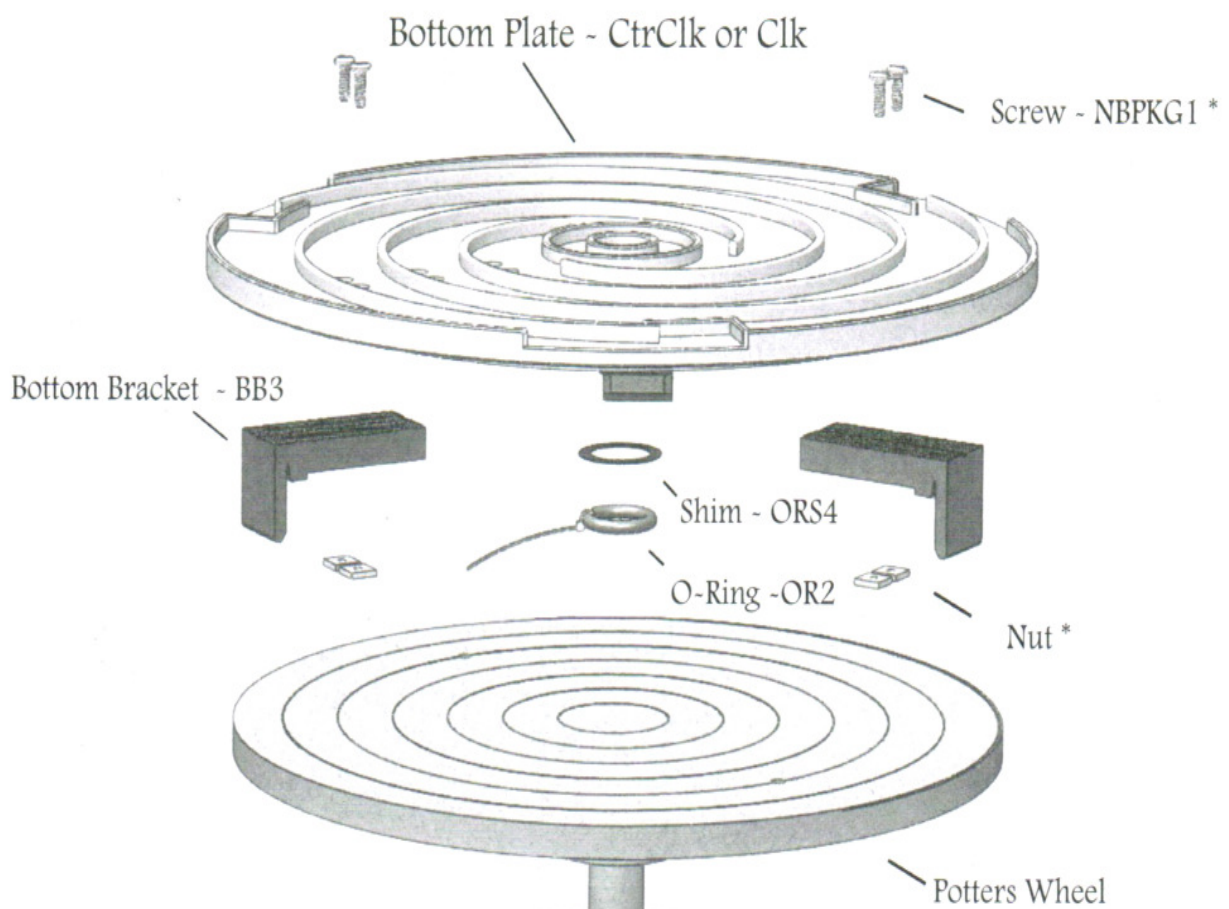

Montageanleitung Giffin Grip

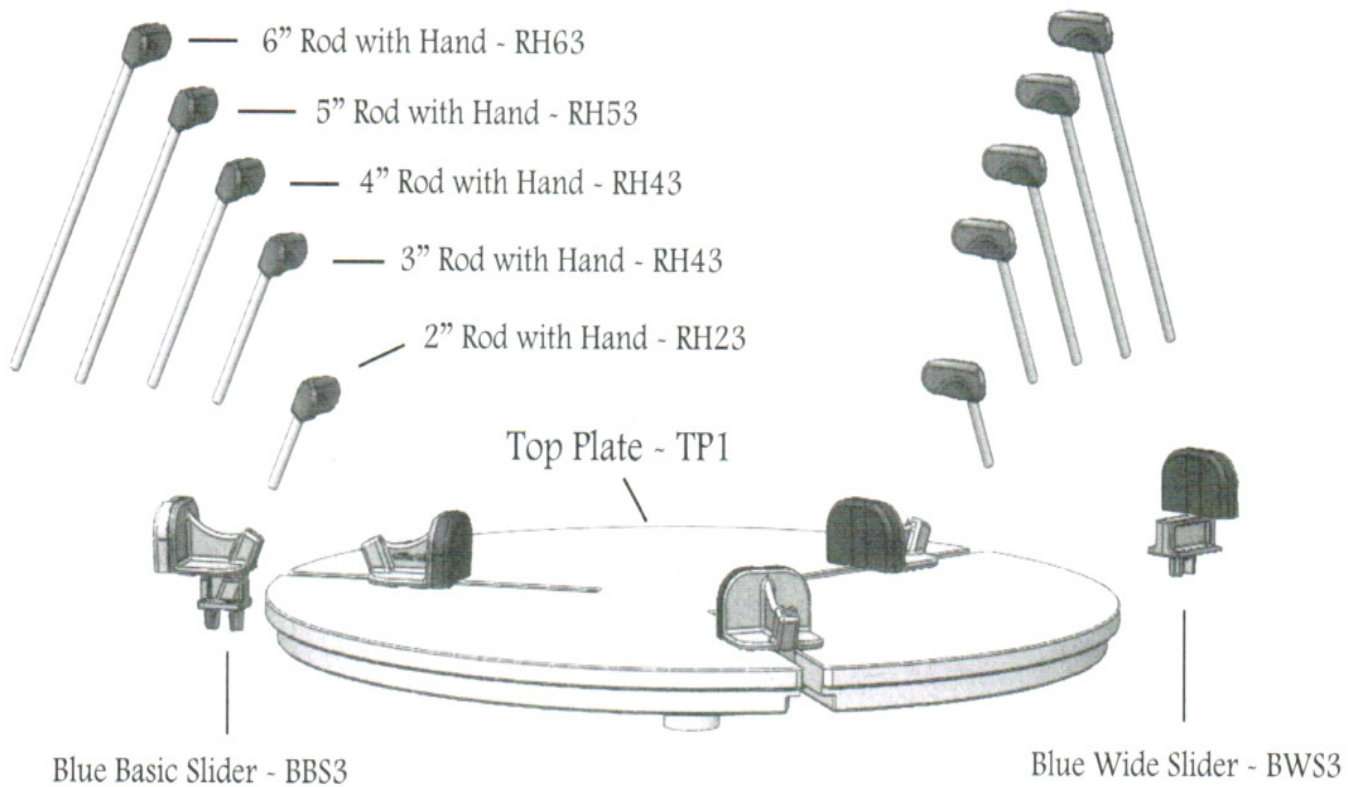
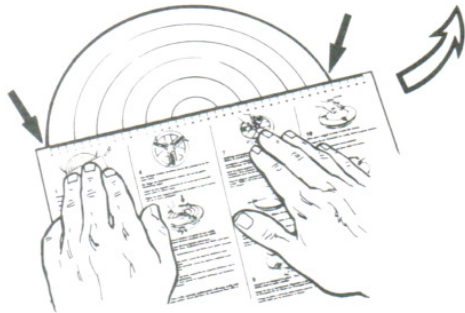

1

Measure diameter of potters wheel.

Messen Sie den Durchmesser des Drehtellers Ihrer Töpferscheibe.

Mida el diámetro de la cabeza del torno.

Mesurez le diamètre du tour.

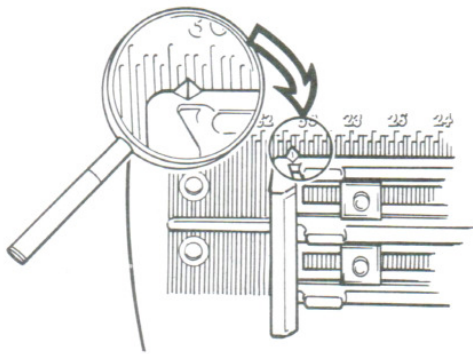

2

Set pointer on bottom bracket to this measurement.

Platzieren Sie den Zeiger der Bodenklammern auf den gemessenen Wert.

Ajuste el marcador en el soporte inferior a la medida del diámetro de la cabeza del torno.

Réglez le curseur du support inférieur à cette dimension.

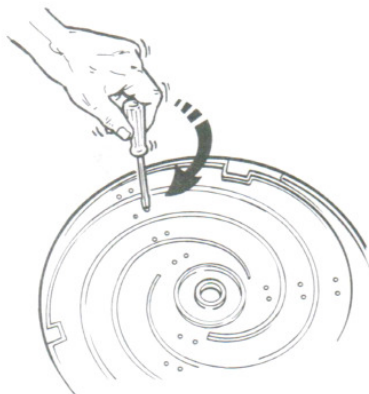

3

Attach bottom bracket with nuts and screws.

Befestigen Sie nun die drei Bodenklammern mit den Schrauben und Muttern.

Fije el soporte inferior con las tuercas y los tornillos.

Fixez le support inférieur au moyen des vis et des écrous.

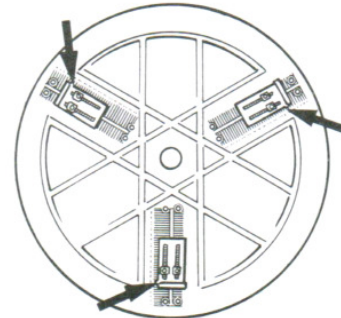

4

Get all three bottom brackets set so the pointer is on the same mark.

Die Zeiger der Bodenklammern müssen alle auf die gleiche Markierung zeigen.

Ajuste los tres soportes inferiores de tal modo que el marcador quede sobre la misma marca.

Réglez les trois supports inférieurs de manière à ce que le curseur soit sur la même graduation.

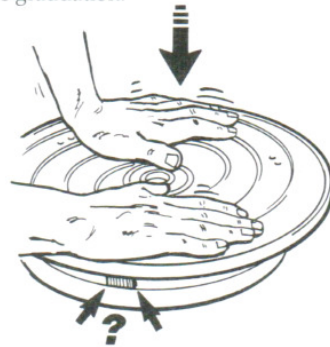

5

Try it out.

If too loose, move bottom brackets in one notch.
If too tight, move bottom brackets out one notch.

Versuchen Sie jetzt die Grundplatte aufzusetzen.

Sollte sie zu locker sitzen, Bodenklammern eine Kerbe nach innen versetzen.

Sitzt sie zu fest, Bodenklammern eine Kerbe nach aussen versetzen.

Pruébelo.

Si está demasiado suelto, mueva los soportes inferiores hacia adentro una ranura.

Si está demasiado apretado, mueva los soportes inferiores hacia afuera una ranura.

Faites un essai.

Si l'outil est trop lâche, rapprochez les supports inférieurs vers le centre d'une graduation.

S'il est trop serré, écartez les supports inférieurs vers l'extérieur d'une graduation.

6

When it fits correctly, bottom plate will snap easily onto your potters wheel and have no movement from side to side.

Bei richtiger Einstellung rastet die Bodenplatte leicht auf dem Drehteller ein und sitzt fest.

Quando esté correctamente ajustado, el plato inferior embonará fácilmente sobre la cabeza del torno y no tendrá movimiento ni juego alguno.

Quand l'outil s'ajuste correctement, la plaque inférieure s'enclenche facilement en position sur votre tour de potier et ne se déplace pas latéralement.

Montageanleitung Giffin Grip

21 22 23 24 25 26 27 28 29 30 31 32 33 34 35 36 37 38 39 40

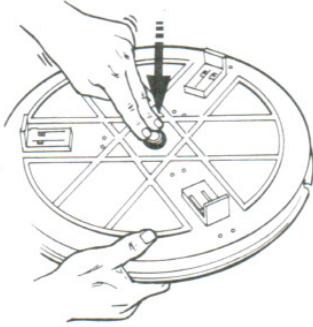

7

Hold top and bottom plates together with the O-Ring. Use O-Ring Shim(s) as needed to take up any play between the two plates.

Grundplatte und Deckplatte mit O-Ring fixieren. Benutzen Sie Unterlagsringe, um Spiel zwischen den Platten auszugleichen.

Junte los platos superior e inferior usando el "O-Ring" (empaques redondo). Si es necesario, use calzas para evitar que haya movimiento entre los dos platos.

Fixez les plaques supérieure et inférieure l'une à l'autre avec le joint torique. Utilisez des cales pour rattraper tout jeu éventuel entre les deux plaques.

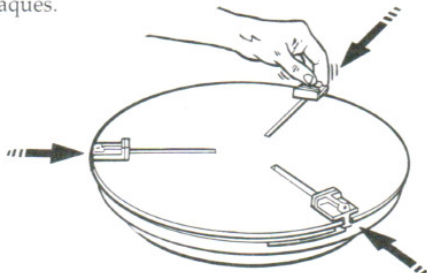

8

Turn top plate until Basic Sliders fit into the entrance gates of bottom plate.

Drehen Sie die Deckplatte, bis die Gleiter in die Öffnungen der Bodenplatte passen.

Gire el plato superior hasta que las correderas embonen en las ranuras del plato inferior.

Faites tourner la plaque supérieure jusqu'à ce que les coulisseaux de base s'adaptent dans les ouvertures de la plaque intérieure.

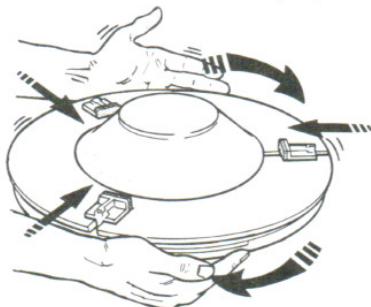

9

Put pot to be trimmed in place. Turn top plate until Basic Sliders start to make contact.

Setzen Sie das zu bearbeitende Werkstück in die Mitte. Drehen Sie die Deckplatte bis die Gleiter das Werkstück berühren.

Coloque la pieza a retornear sobre el plato superior. Gire el plato superior hasta que las correderas se toquen.

Mettez le pot à tourner en place. Faites tourner la plaque supérieure jusqu'à ce que les coulisseaux de base commencent à faire contact.

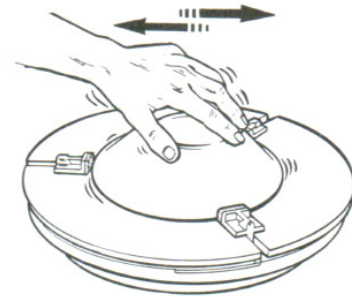

10

Give pot a wiggle to help it into the center.

Bewegen Sie das Werkstück ein wenig, damit es genau zentriert wird.

Golpée la pieza ligeramente hasta centrarla.

Déplacez légèrement le pot pour aider à le centrer.

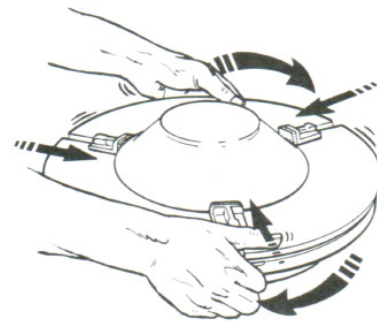

11

Gently tighten top plate again. For best results, do final turn using both hands with equal pressure.

Drehen Sie die Deckplatte vorsichtig weiter. Es empfiehlt sich, die letzte Drehung mit beiden Händen und gleichmäßigem Druck auszuführen. Jetzt können Sie das zentrierte Werkstück unbesorgt bearbeiten.

Suavemente, apriete de nuevo el plato superior. Para obtener mejores resultados, déle el último giro presionando parejo con las dos manos.

Resserrez légèrement la plaque supérieure. Pour obtenir les meilleurs résultats, faites le tour final en appliquant la même pression des deux mains.

Trim with confidence!

Viel Vergnüen!

Retornee con confianza!

Toumez en toute confiance!



Montageanleitung Giffin Grip

Safety Considerations

Avoid entanglement with hands, long hair, loose clothing, apron strings and trimming tools.

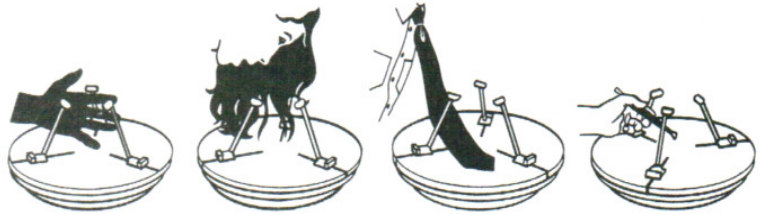

This product has been designed from day one with your safety in mind. All corners are rounded, the rods slip out, and the complete unit can pull away from the potters wheel. With thousands in use, we know of no injuries from using a Giffin Grip, but keep in mind that some risk is inevitable in practically everything we do. Be especially careful with children in the studio, their imaginations are frequently better than ours.

Trade Secrets

To keep pots from warping as they dry, place on level shelves, away from direct sun and breezes. Turn pots upside down as soon as possible. Protect delicate rims with thin foam or clay pads. Small pots can be lifted up. Giant pots can be held from the inside out. If lubrication is needed, use a vinyl cleaner such as Armorall.® Dry pots can be held more firmly than wet pots. Keep your trimming tools sharp to avoid chatter. There are no "rules" for using the Giffin Grip. Do whatever works for you within the limits of safety.

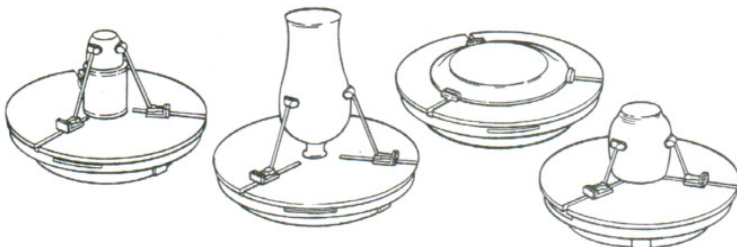

Replacement parts are available.

Please contact your clay supplier.

Price subject to change without notice.

Basic Sliders (set of 3)	BS3
Wide Sliders (set of 3)	WS3
Bottom Brackets (set of 3)	BB3
Screw & Nuts (6 of each)	NBPKG1
Foam Pads (set of 3)	FP3
2 O-Rings w/pull tabs	OR2
O-Ring Shims (set of 4)	ORS4
2" Rod with hand (set of 3)	RH23
3" Rod with hand (set of 3)	RH33
4" Rod with hand (set of 3)	RH43
5" Rod with hand (set of 3)	RH53
6" Rod with hand (set of 3)	RH63
Top Plate	TP1
Bottom Plate*	BP1

*Specify Counter Clockwise (US Standard)
or Clockwise (Japanese)

Spare Parts, Warranty and Repairs

For lost or broken parts contact your local ceramics dealer. They should carry all spare parts in stock and back the guarantee. If unavailable try ordering on-line or contact us directly.

International Guarantee

90 days money back if not completely satisfied.

10 years free replacement of parts that wear out or break in normal use.

Brian Giffin, President, GIFFIN TEC inc.

